

# DanPumps S-WN Pumps

Vertical & horizontal wastewater pumps for dry pit installations





## DanPumps S-WN Pumps for Wastewater Applications

The dry installed DanPumps S-WN pumps are used for horizontal and vertical mounting. The pumps are compact in design to meet a wide range of service conditions. They are driven by an energy saving air-cooled IEC motor and connected to the piping with flanges on both suction and discharge sides.

### The Wastewater Program

With the range of pumps from the small S-WN1 to the large S-WN5, we cover the need from light industrial effluents to heavy duty wastewater jobs from both cities and industries. The flow rate varies from 68m<sup>3</sup>/h to 4000 m<sup>3</sup>/h with connections from DN80 to DN600. The S-WN pumps can be used in many different applications by adjusting the motor size and impeller type, the solution can easily be customized to comply with your requirements.

### Quality & Sustainability

We are committed to providing our customers with the best products at the highest quality standards in the industry. We provide complete testing facilities, capable of demonstrating pump performance and testing ancillary equipment to ensure smooth commissioning and startup procedures. Certified in accordance with ISO 9001:2015 and professional pump services - we can ensure the right solution that meets your specific needs:

- High pump efficiency
- Non-clogging impellers
- Life-long reliability





*Fast lock latch bolt*



*Double Mechanical Cartridge Seal*



*B-tween impeller*

### Unique Cartridge Seals & Easy Maintenance

Our unique double mechanical seals are installed in a user-friendly cartridge and make it possible to change the seal without using any special tools – it eliminates any risk of improper installation.

### Fast Lock Latch Bolt

Another unique feature for the DanPumps S-WN-line is the fast lock latch bolts which makes it easy to separate the pump from the motor. This feature is very popular among the service staff, as it reduces maintenance downtime considerably.

### Higher Efficiency with Adjustable Wear-ring.

The wear-ring reduces the hydraulic loss between the impeller and the wear-ring. With this feature, the wear-ring can regularly be adjusted to optimize the pump's efficiency.

### Premium Efficiency Motor

A Premium Efficiency motor as standard is the best way to reduce energy use as it improves efficiency without affecting the risk of blockage. An air-cooled IEC motor from 2,2 to 200 kW. Suitable for pumping wastewater and sewage from buildings and sites in domestic, commercial, industrial, and municipal areas.

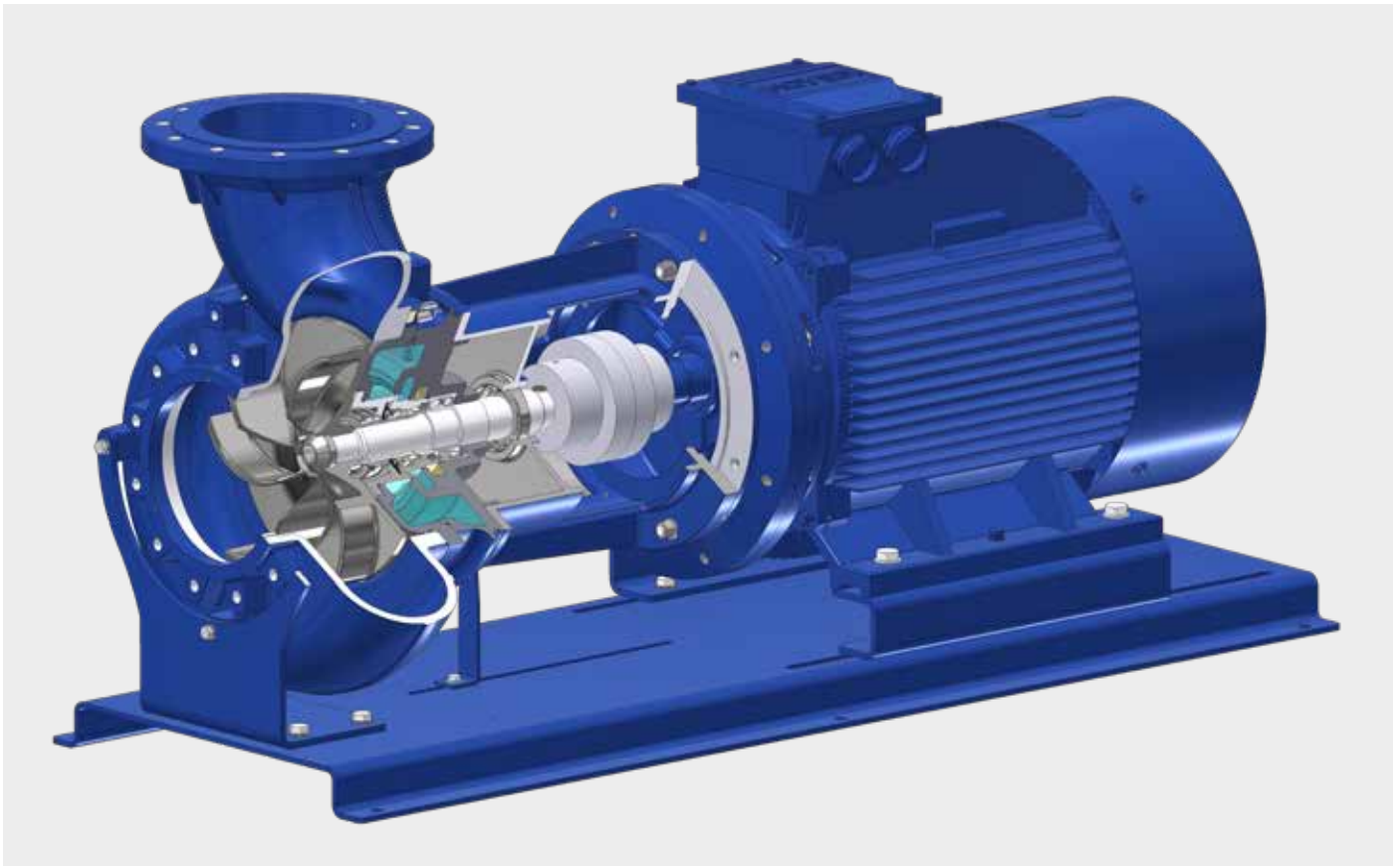

### High Efficiency with Unique Features

The design of the S-WN pump is a combination of high efficiency, intelligent design and practical features.

The efficiency of the pump is essential to reduce the running costs of the pump while at the same time reducing the carbon footprint, which is achieved by the design of the impeller and use of high-efficient motors – it gives you a user-friendly pump with a long-life cycle. Easy service will reduce maintenance costs, as it is simplified without the need to dismantle the entire pump.

The motor and hydraulics of the S-WN pump create a great pump reliability and high pump efficiency, which means:

- Reduced risk of overflows
- Reduced risk of interrupted service
- Reduced breakdown costs
- Reduced maintenance costs

### Features:

- All impellers fit in the same volute
- Cartridge seal
- High-efficient motors from well-known suppliers
- Easy maintenance
- Dry-installed, therefore no risk of contamination
- No need for entry into pump stations
- Easy removal of the motor without disconnecting the pump
- Good service access to pump suction side
- Built-in frequency converter up to 22 kW





## Horizontal or vertical pumping in dry installations

### Vertical

- Requires a smaller service area than a horizontal pump
- Adjustable legs which make installation easier
- Top pull-out construction, easy access to the pump parts and easy removal of the motor
- Easy disassembly when making service by crain

### Horizontal

- Easy dry installation
- The pump is on a baseplate, where sliding makes service easy
- Pump parts are easily accessible
- Suitable for almost all indoor applications due to its low headroom requirements

## Wastewater collection process

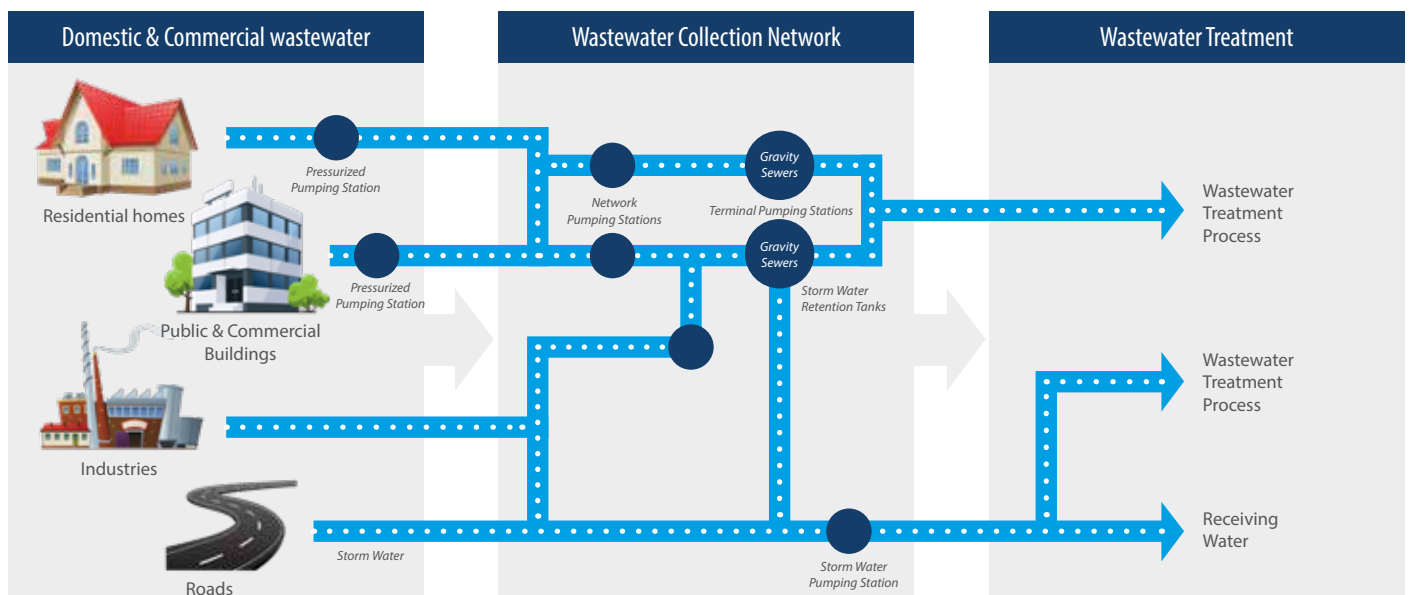

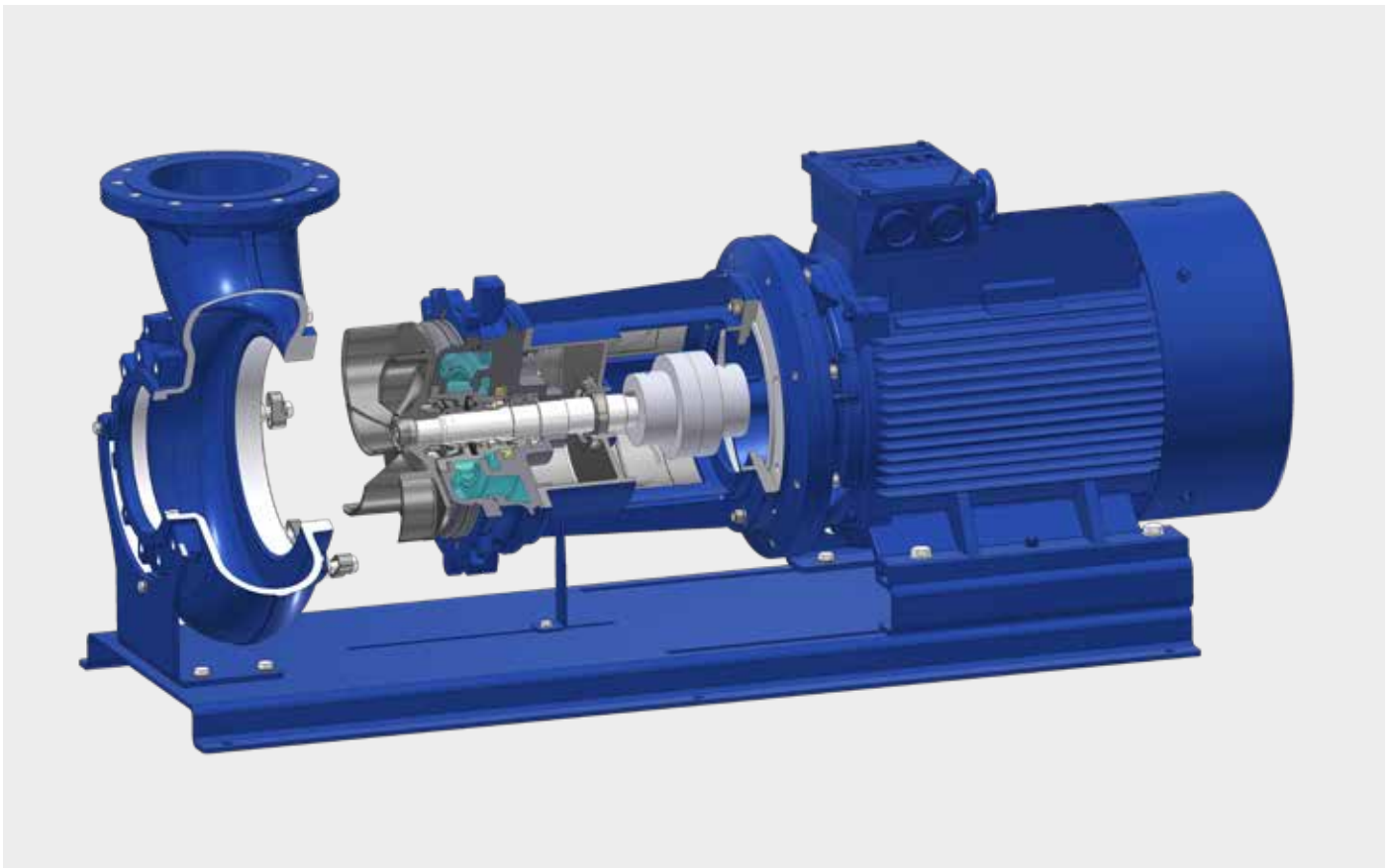

### Construction

- Horizontal version mounted on a steel base plate, vertical version mounted on adjustable legs
- Pull-out design allows easy removal of the motor without disconnecting the pump from the pipework
- Cartridge seal with double mechanical seals - the service time of changing the seal is reduced compared to a normal double mechanical seal
- Flexible coupling prolonging the lifetime of a pump
- Available in standard and explosion-proof versions in accordance with international standard ATEX operation is 75 °C
- Maximum ambient temperature: +75 °C
- Motor protection type: IP 55
- Insulation Class: F to 155 °C (Class H as an option)
- Connections from DN80 to DN600

### Main Benefits:

- Dry-installed
- No risk of contamination
- Pull-out design
- IEC air-cooled motors IP55 (ATEX approved is optional)
- Flexible coupling for gentle operation of the pump

### Main Applications:

- Clearwater
- Polluted water
- Heavily-polluted sewage containing solids, fecal slurry and sludge



# S-WN Pumps Performance Curves

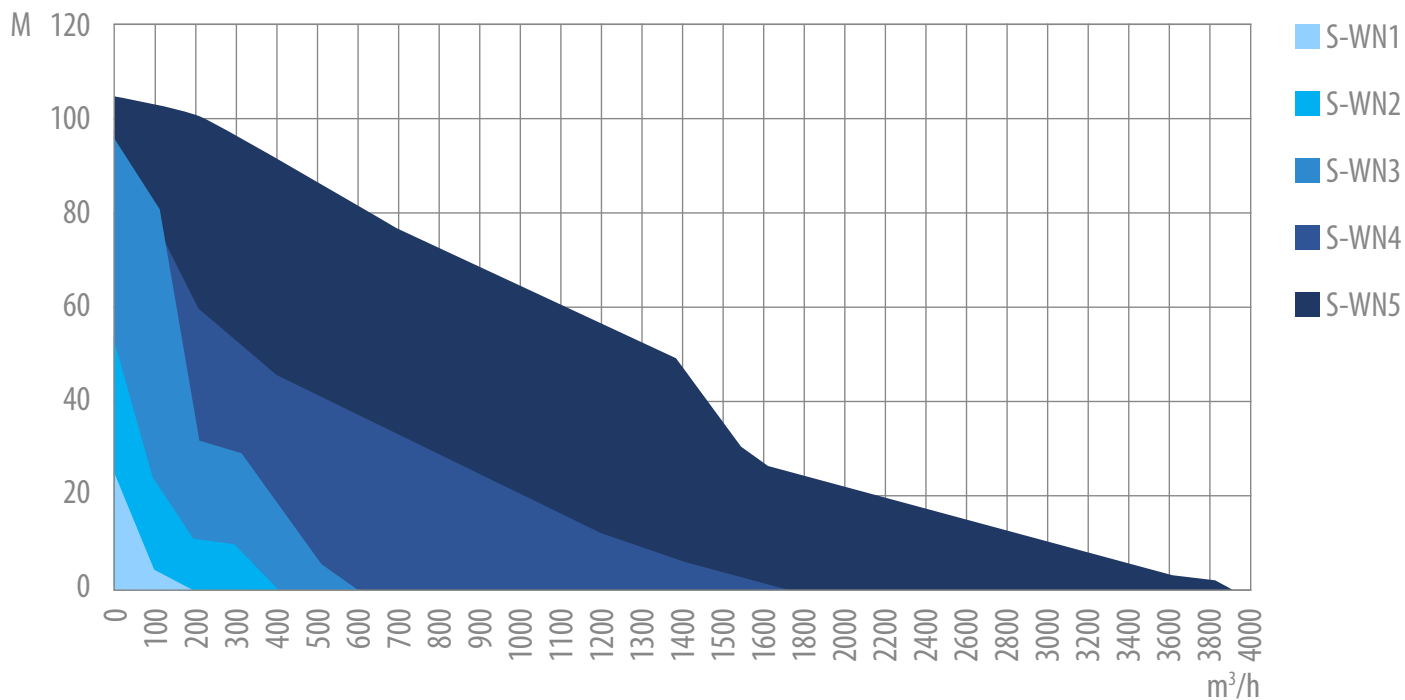

## Choose the Most Optimal Impeller:



- **One or two channel impeller**  
Higher efficiency (70-80%).  
Possibility of clogging.



- **B-tween impeller**  
Less efficient (60-75%).  
Lower possibility of clogging.



- **Vortex impeller**  
Less efficient (30-40%).  
Clogging free due to free passage, therefore it is reliable.



Vortex impeller made of AISI 316 stainless steel.

## Materials

<b>Pump Housing, Base Elbow, Sealing Housing</b>	Grey Cast Iron GJL-250 (GG25) A-48 Class35
<b>Impeller (cast iron), adapter</b>	Ductile Cast Iron GJS-400-15 (GGG-40) A536 GR 65-45-15
<b>Stainless Impeller (option)</b>	Stainless Cast Steel W.Nr.1.4401 / AISI 316
<b>Shaft</b>	Stainless Steel W.Nr.1.4057 / AISI 431
<b>Seal Sleeve, Screws</b>	Stainless Steel W.Nr.1.4301 / AISI 304
<b>O-rings</b>	Nitrile/ NBR
<b>Oil</b>	Mobil DTE 24 Premium Hydraulic
<b>Mechanical Seal</b>	Media Side: SIC/SIC Cooling Side: SIC (Carbon)
<b>Motor</b>	Hoyer /IE3 / Class F Optional as class H

**Impeller are delivered in cast iron, stainless steel and duplex as an option**

## About Rotadyne

A privately-owned Australian family business, Rotadyne is situated in North St Marys, Sydney, and began rotational moulding in 1973. The Rotadyne story is one of continually seeking excellence and pushing the boundaries of innovation.

Rotadyne has a passion for custom moulding, and we have worked with countless iconic clients which have been highly successful in dominating their industry market, both locally and internationally. We aim to afford you with the flexibility to create and customize your product exactly as you envision it.



## Design and Manufacturing

“Custom” doesn’t just describe our ability to create purposeful designs and introduce new product features. It also refers to our flexible manufacturing strategies which are adjusted to suit each individual project. We have the industry expertise to manage this process on behalf of our customer.

We guide our clients through the whole process, from design, to tooling, to manufacture. The end result is an optimized experience, taking your smart ideas and turning them into tangible, market leading products.

## Quality Products

Rotadyne supplies a range of industry products, such as Marine equipment, pool heating fittings, lighting, and more. We take pride in delivering high quality commodities, and in our capabilities for customisation.

In addition to our product ranges, we also provide packaged systems for waste water, water management, and chemical industries, including high quality tanks, pumps, and required instrumentation.

